

**G U I
D E D
S U
R G E
R Y**



B&B DENTAL
IMPLANT COMPANY



TABLE OF CONTENTS

WORKFLOW

ANALOGUE WORKFLOW.....	4
DIGITAL WORKFLOW.....	5

CONEXA CONNECTION

.....	6
-------	---

GENERAL INFORMATION

HOW TO USE THE SURGICAL KIT	7
WHEN IT IS POSSIBLE	8
FILES MATCHING.....	9

TYPES OF SURGICAL TEMPLATES

TOOTH-SUPPORTED TEMPLATES	10
MUCOSA AND BONE-SUPPORTED TEMPLATES	11

GUIDED SLEEVES

.....	12-13
-------	-------

GUIDED SURGICAL KIT

.....	14-15
-------	-------

FIXING DEVICES

LATERAL AND CRESTAL PINS.....	16
-------------------------------	----

INITIAL SURGICAL INSTRUMENTS

MUCOTOMES	17
CRESTAL LEVELLER	18
LANCE DRILL	19

PREPARATION INSTRUMENTS

GUIDED DRILLS.....	20
COUNTERSINK DRILLS	22
COMPACTORS.....	23

MOUNTERS AND DRIVERS

MOUNTERS - MOUNTER EXTRACTOR.....	24
DRIVER FOR MOUNTERS - DIRECT DRIVERS.....	25

KEYS, RATCHETS AND EXTRACTOR

PROSTHETIC SCREWDRIVERS - EXTRACTOR KEY.....	26
RATCHETS - STRAIGHT MANUAL KEY	27

COMPONENTS FOR MUA

REAMER - POSITIONERS	28
----------------------------	----

OFFSETS FOR ENHANCED SOFT TISSUE THICKNESSES

GENERAL MEASUREMENTS	29
GUIDED SURGERY KIT +2 +4 OFFSET.....	30

GUIDE SYSTEM SOFTWARE

.....	31
-------	----

PROTOCOLS

SLEEVE \varnothing 4.2 (HARD BONE - SPONGY BONE).....	32
SLEEVE \varnothing 5.5 (HARD BONE - SPONGY BONE).....	33

PACKAGING

.....	36
-------	----

DIGITAL FRAMEWORKS

.....	38
-------	----

DIAGNOSIS 1

At this stage, it is important to ensure that the patient's mouth opening is large enough to accommodate guided surgery instruments, that bone thickness and tooth spacing are suitable to support the templates, and to check for any metal parts that could make it difficult to take a clear CAT scan image.



PRECISION IMPRESSION TAKING WITH IMPRESSION MATERIAL 2

Impression accuracy is key. Bicomponent silicones are recommended for *partially edentulous* patients, whereas polyether based materials are preferred for *full edentulous patients*.



RADIOGRAPHIC TEMPLATE 3

In edentulous patients and patients with large metal restorations that would cause scatter on CAT scans, a radiographic template is indispensable to match DICOM file and Model correctly. This step can be omitted if the patient has a sufficient number of well distributed, stable teeth.



CONE BEAM (CAT) 4

In order to obtain a clear, usable image, the Cone-Beam machine must be set with accurate parameters and the template must be positioned correctly.



Please refer to the check list available to download from our website for the settings.

PATIENT DATA DIGITISATION AND COLLECTION 5

The data collected from the patient need to be digitised for the software to be able to read them. Summing up • the bone structure is provided by the DICOM file obtained through the CAT scan • soft tissues and teeth are obtained through the STL of the scanned model • the position in space needed to achieve the superimposition of the files mentioned above is provided by the radiographic template that is properly positioned in the mouth during the CAT scan and on the model in the scan.



PLANNING 6

The files acquired can be imported into the software for the planning process. The matching process is the key moment when all the information gathered is superimposed to create a clear overall image that can be used to plan implant position. Matching can be done using the radiographic template or, in partial edentulous patients, also the teeth.



B&B Dental Guide System is the free planning software available to download from the B&B Dental website. B&B Dental's in-house laboratory offers case planning and template modelling services.

SURGICAL TEMPLATE MANUFACTURING 7

The surgical template can be modelled using the planning or modelling software. It is important to evaluate the tolerance between sleeves and equipment parameters in order to ensure proper fit.



B&B Dental's in-house laboratory offers template printing services.

SURGERY 8

On the day of the surgery, it is essential to have template, implants and guided surgery kit available.



INTRAORAL IMPRESSION 2

The intraoral impression is used in the digital workflow. This approach is only possible in partially edentulous patients with stable, well distributed residual teeth and without large metal restorations, so that the intraoral scanners can acquire accurate images.



3 4

The digital workflow does not require a radiographic template and the patient will not be wearing any device during the DICOM file acquisition.



Guided surgery is also well suited for a full digitisation of the workflow. In this case, the impression is taken digitally. Hence, it is not necessary to scan and digitise the model, and no radiographic template is manufactured to match the model with radiographic data, as the matching is done with the aid of residual teeth.

CONEXA CONNECTION

PROSTHETIC SCREW

It sets abutment and implant with full conometry. There is no failure risk because it is not loaded

PLATFORM SWITCHING

Reduction of bone loss
Long-term aesthetic stability
Hinders bacteria infiltration
Improved emerging aesthetic profile
Force distribution

TAPER CONNECTION

"MORSE-TYPE TAPER AT 5° TOTAL

Cold soldering
Eliminates micro-movements
Eliminates through bolt loosening

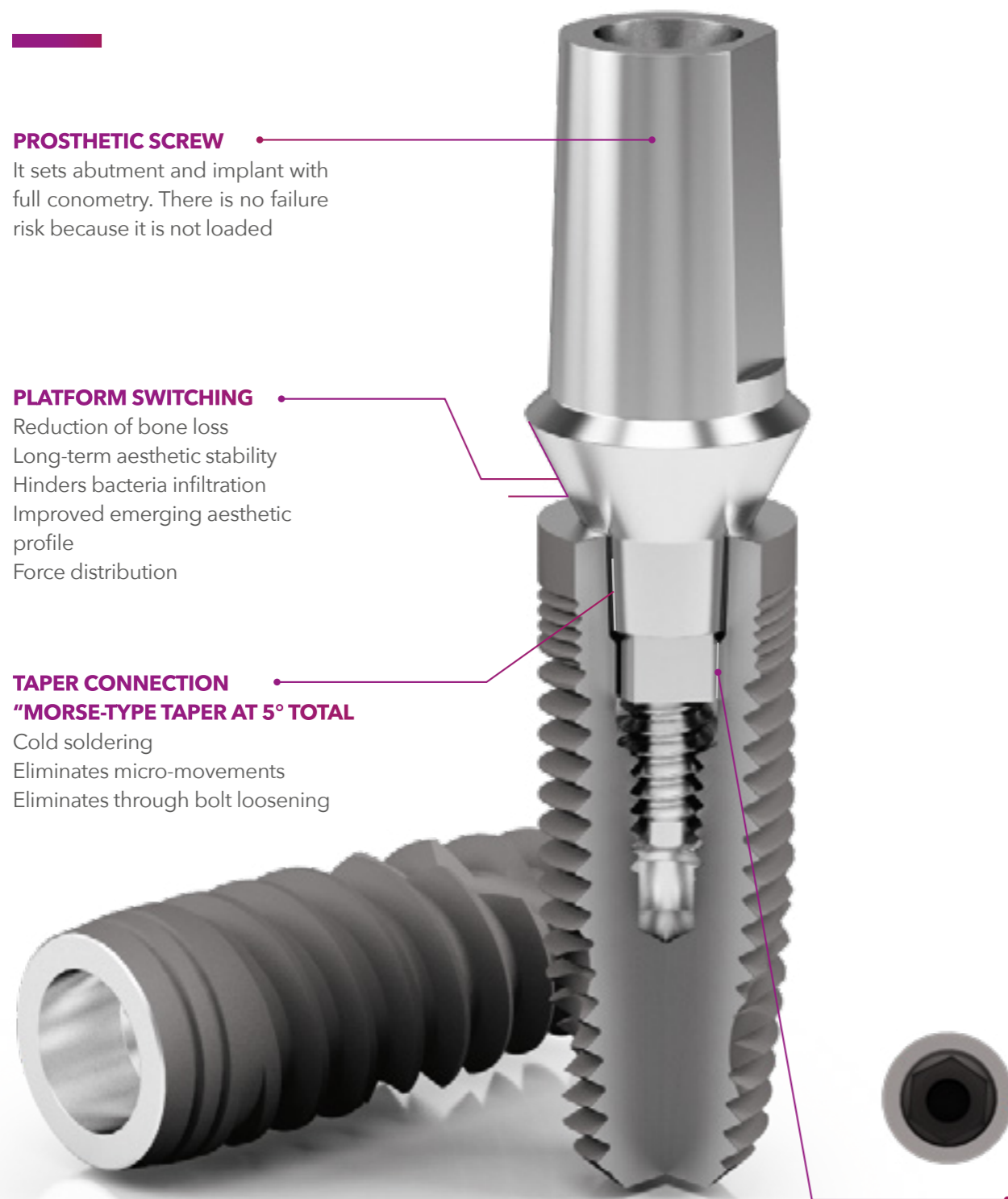

The various lines of the B&B Dental implant family (SLIM, 3P, EV and WIDE) allow you to use the most suitable implant design and size for each surgical site. The implants are available in diameters of 3.0 - 3.4 - 3.5 - 4.0 - 4.5 - 5.0. The uniform implant connection for upper-diameter implants at 3.40 offers different surgical options separated by morphology (3P - narrow thread - EV - large thread) but with a uniform prosthetic platform facilitating the processing and selection of prosthetic abutments.

INTERNAL HEXAGON

It ensures anti-rotation feature for absolute abutment positioning

HOW TO USE THE SURGICAL KIT

It is useful to know the surgical accessories compose the kit before proceeding with the description of the operative protocol. The morphology of the instruments inside the B&B DENTAL SURGICAL KIT is specifically designed for the guided insertion of the SLIM, 3P and EV line implants. The neck of the drills allows for a precise insertion inside the guided sleeve determining the depth of the osteotomy with a known full-travel stop at a distance of 9 mm from the crestal edge of the bone.



The materials used for the production of devices manufactured by B&B Dental were selected based on the properties indicated for their intended use, in compliance with Directive 93/42 implemented in Italy by Law 46/97, the attached essential requirements, point 7.1.

The surgical kit and the instruments contained in it are sold in non-sterile packs; the codes, description and lot number are listed on each package. It is essential that they are cleaned, disinfected and sterilized before use, according to the instructions on the enclosed leaflet.

The wear down of the drills depends largely on the type of drilled bone density: harder bones carry greater wear on the instruments. It is recommended to check the maintenance status of the residual cutting capacity after each operation with particular focus on the initial tools of the protocol.

IMPLANT LINES FOR GUIDED KIT



NOTE

The Wide line can not be used in guided surgery.

WHEN IT IS POSSIBLE

OPENING OF THE MOUTH

Guided surgery is a highly versatile technique that has made great strides in recent years. But we must remember that there are limits to the application of this technique to be evaluated before beginning this process. An important point is the patient's ability to keep its mouth open and the assessment of the overall dimensions of the drills and masks to be used. If the necessary conditions are not met, the evaluation of other approaches may be effective for the treatment of the patient.



INTERDENTAL SPACE

The space between teeth should be measured with an instrument in order to allow for the precise positioning of the guided sleeve according to the diameter of the pre-selected implant suitable to the surgical site.

4.2 MM Ø SLEEVE

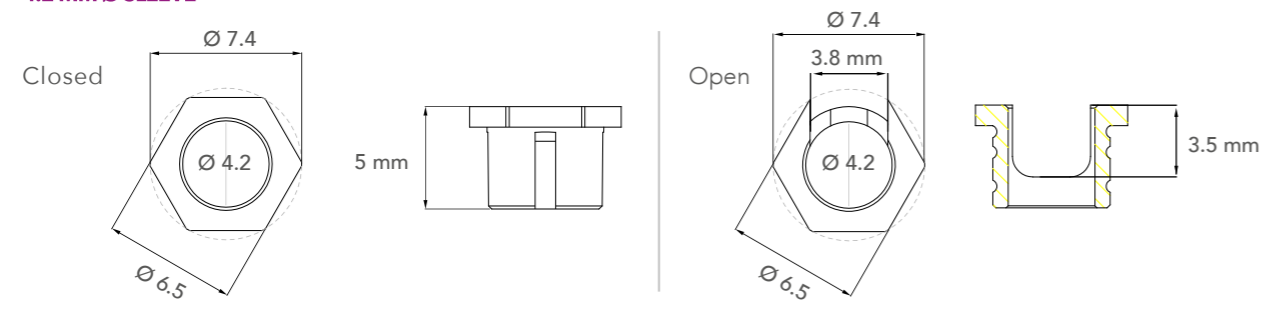

5.5 MM Ø SLEEVE

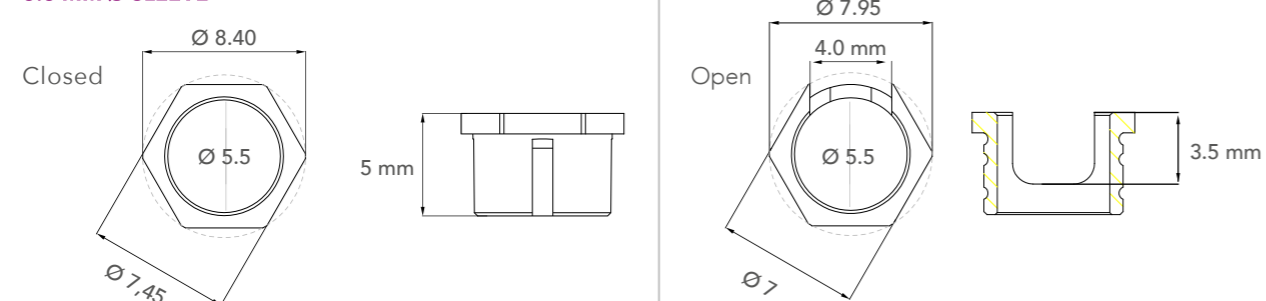

FILES MATCHING

In order to create the surgical template, the digital acquisition of the STL file of the model or of the mouth and the DICOM file deriving from the cone beam is necessary. In order to match the data coming from the two files and evaluate the mucosal thicknesses (STL) and the dimensions and shape of the bone (DICOM) during surgical template planning, it is necessary to use radiopaque markers. These markers are small spheres recognized by the software that allow for the perfect placement of the two files on each other. Markers should be placed homogeneously on the aesthetic trial of the prosthetic project.

MATCHING WITH RESIDUAL TEETH

In the case of a project that involves a patient with residual teeth, the image matching can be done both with the correctly positioned markers or with the matching of the residual teeth themselves. It is important to pay particular attention to the presence of metal reconstructions that can generate scattering. In such case, it will be necessary to position the markers as described below.

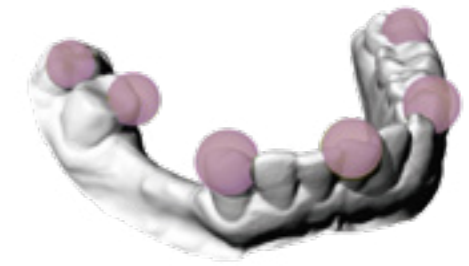

MATCHING WITH RADIOPAQUE MARKERS

In the eventuality of a patient with a total edentulism, in order to allow for the matching of the files derived from the cone beam and of the extraoral and / or intraoral impressions, it is important to place the radiopaque markers forming triangles as shown in the image. In order to guarantee a high degree of precision, the reduced dimensions of the B&B Dental markers allow for easy image acquisition in the cone beam, thereby avoiding problems of falsification or incomplete acquisition (especially with large markers) in the case of a cone beam with an insufficient field of view (FOV).



1 CF X 5 PZ
GD-SFERE



QUANTITY	CODE
1 cf x 5 pz	GD-SFERE

TYPES OF SURGICAL TEMPLATES

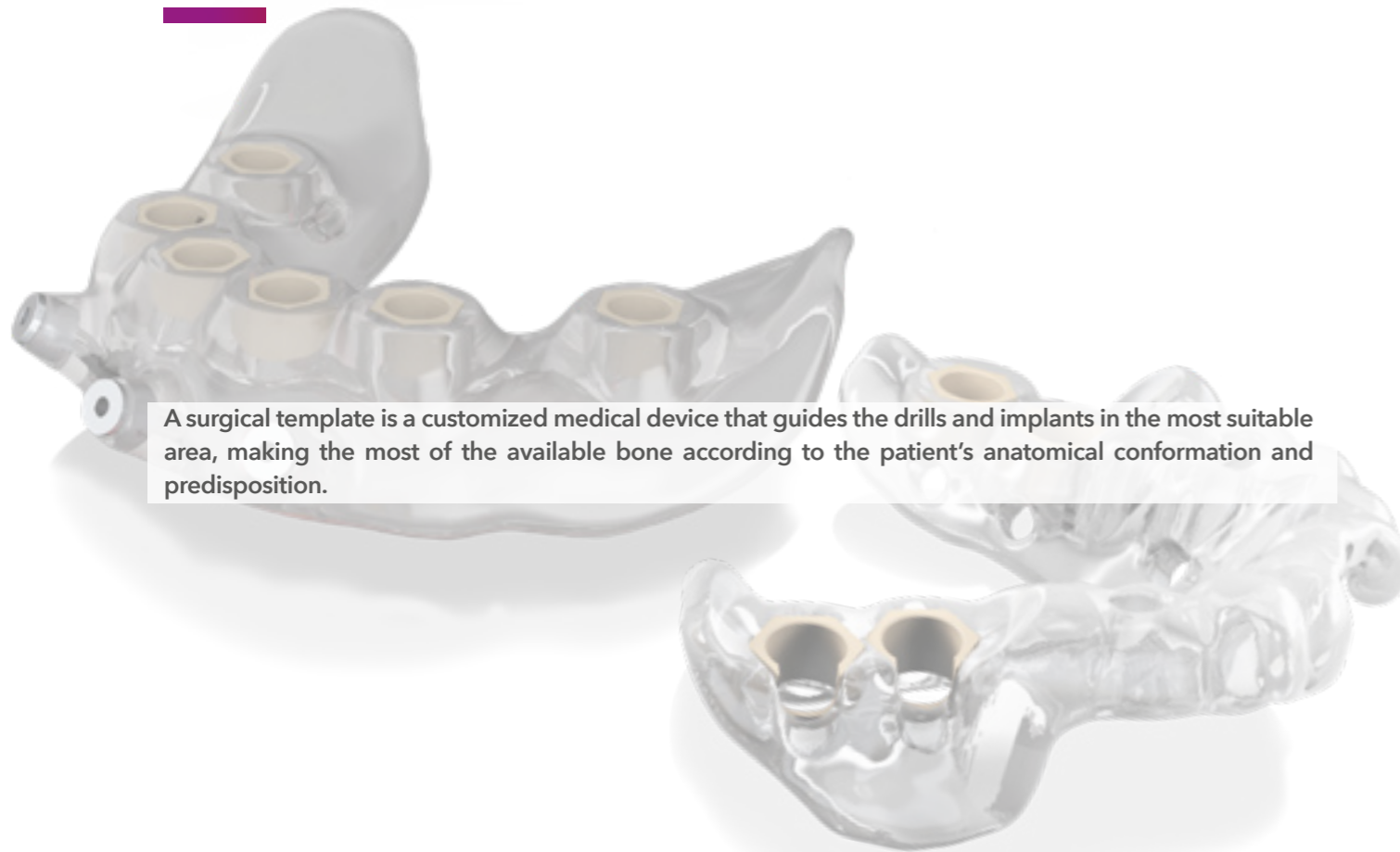

A surgical template is a customized medical device that guides the drills and implants in the most suitable area, making the most of the available bone according to the patient's anatomical conformation and predisposition.

DENTAL SUPPORT TEMPLATES

If the patient has a residual dentition, the template can use it as a support to achieve stability. If you require greater stability, you should use crestal pins. The crestal pins should be inserted after using a lance drill (3) and be chosen with a diameter that is consistent with the sleeve and the length depending on the implant to be inserted.



MUCOSAL SUPPORTED TEMPLATE

When there are no teeth present, the template will have an exclusively mucous support. In this situation, it will be necessary to use lateral pins and / or crestal pins. The lateral pins should be inserted after drilling the bone with the pin drill (C) inside the holes with dedicated sleeves, positioned in the vestibular area. The template in this phase must be held in place with a silicone bite.

However, lateral pins may not be enough sometimes; in this case you can use crestal pins, which are screws that are fixed in the implant sleeves after creating a hole with the lance drill (3) and be chosen with a diameter that is consistent with the sleeve and the length depending on the implant to be inserted.



BONE SUPPORTED TEMPLATE

The bone-supported templates rest directly on the bone once the soft tissues have come off, and are adopted in cases where the bone appears to be irregular in shape and therefore an osteoplasty is required. This type of template should be fixed with lateral pins, after drilling the bone with the suitable drill (C). Also in this case, the use of crestal pins can increase stability if necessary.

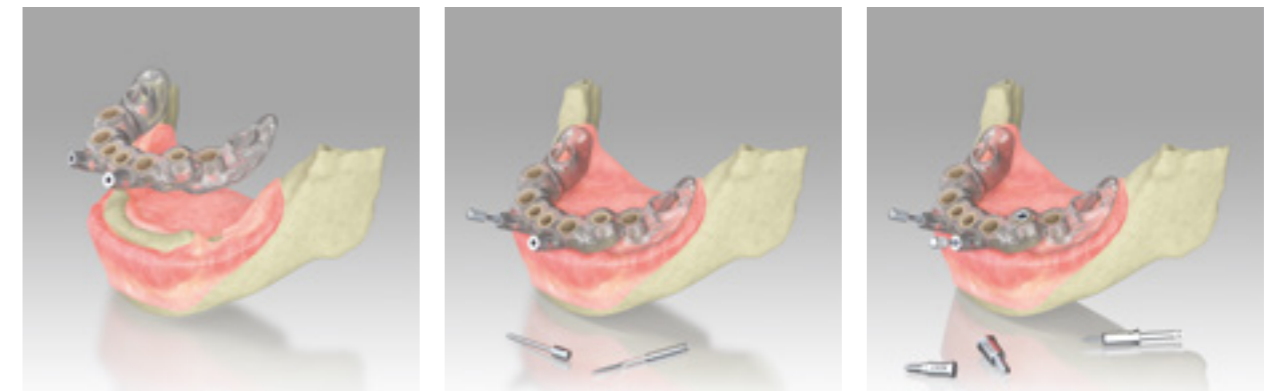

GUIDED SLEEVES

The guided sleeves can have two dimensions and are presented as cylinders included in the surgical templates. They have the main function of guiding the surgical instruments during the preparation of the implant site by guiding the position and inclination of the drills. The sleeves are generally incorporated into the surgical templates and, if necessary, can be supplied separately.

The sleeves have an external hexagon that allows you to correctly position the internal implant hexagon for prosthetic purposes, allowing for the correct position of the inclined abutments in regards to the prosthetic project. They are 5.0 mm high with a 4.2 mm (small sleeve) or 5.5 mm (large sleeve) internal diameter hole and provide a precise full-travel stop at 9 mm from the crestal edge of the bone on all instruments.

LATERAL OPENING

It provides an easy access to the operative site

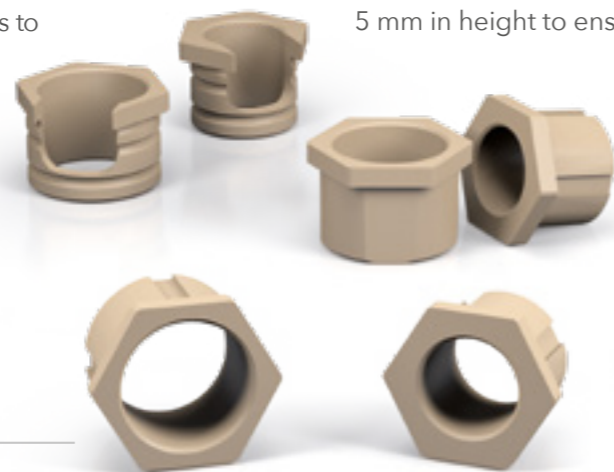

ONE HEIGHT

5 mm in height to ensure a stable and safe guide

TWO DIAMETERS

A guaranteed guide for any implant diameter













HEXAGON

It provides an exact indication of the position of the hexagon implant



SLEEVES WITH LATERAL OPENING

Sleeves with a lateral opening are available for use in the posterior sets where there is difficulty in inserting the drills from above. The lateral opening allows for an easier access in areas where the length of the drills would be a hindrance. Thanks to the lateral opening, which is also described in the guide, it is possible to pass the drills laterally.

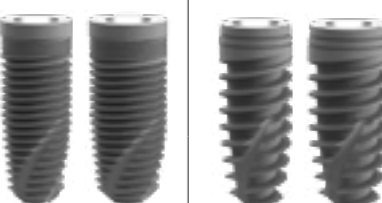
Ø SLEEVES	SLEEVES	MOUNTERS	IMPLANT		
Ø 4.2	 GD-706 1 cf x 4 pz	 +2	 +4	 SLIM 3.0/3.4	
	 GD-764P 1 cf x 10 pz	 GD-768/1	 +2 GD-768/12	 +4 GD-768/14	 3P 3.5/4.0 EV 4.0
	 GD-703P 1 cf x 10 pz	 GD-768/2	 +2 +2 GD-768/22	 +4 +4 GD-768/24	 3P 4.5/5.0 EV 4.5/5.0

SLEEVES MATERIAL

B&B Dental pays particular attention to materials; the sleeves supplied are in peek, a material that is finding more and more applications in the dental sector. In this particular case, peek has greater precision as it is single-use, avoiding the friction and overheating of metal sleeves. Greater precision between sleeve and drill leads to less tilting of the drill itself.

UPPER TRAY

LOWER TRAY

GUIDED SURGICAL KIT

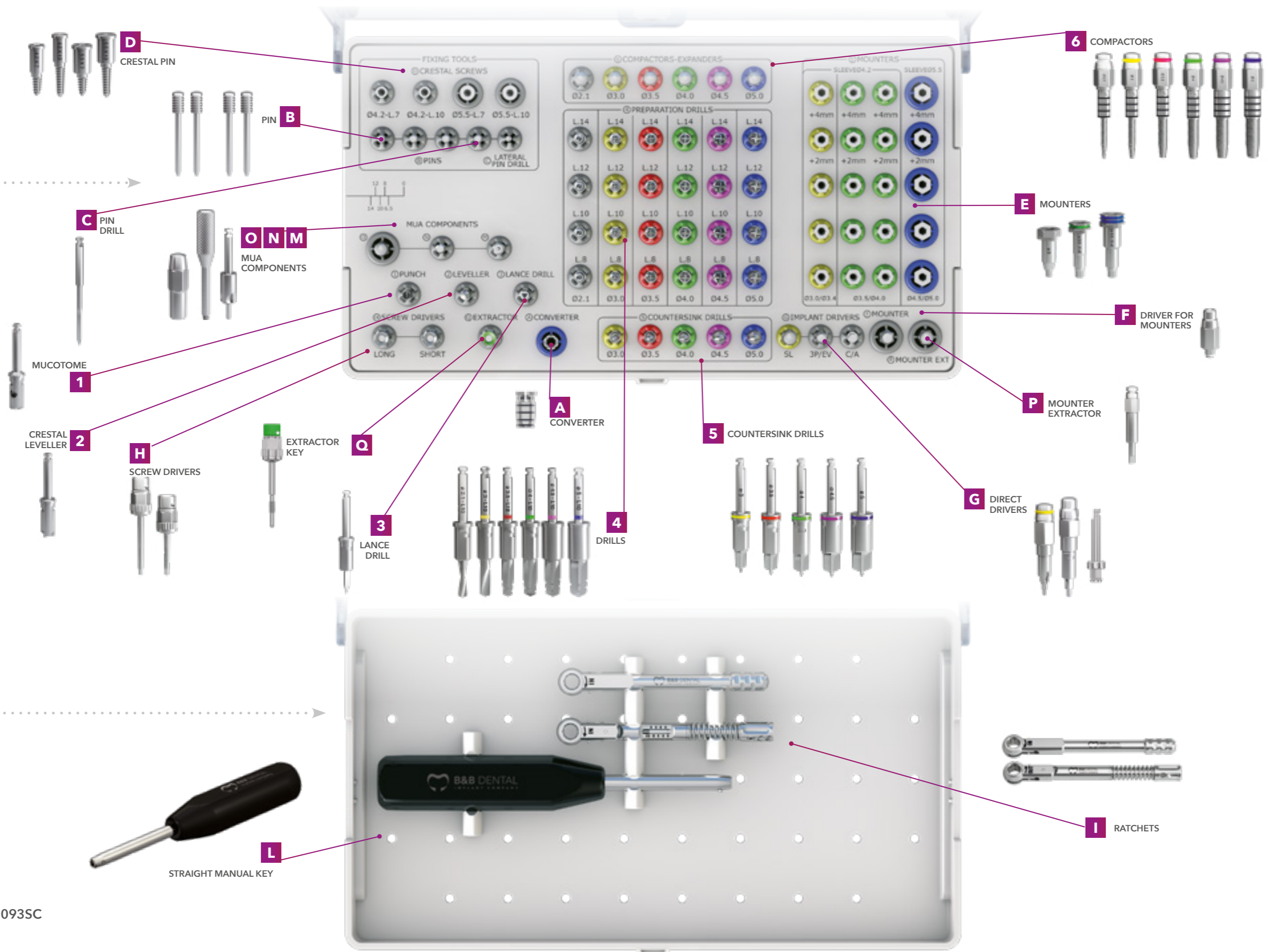

FIXING DEVICES

B LATERAL PINS AND **D** CRESTAL PINS

Before starting the surgery, you must make sure that the mask is stable. With dental support templates, you may find it unnecessary to fix the mask in place. However, in order to anchor the drilling template in its correct position and avoid micromovements during surgery, all other cases where fixing the mask is necessary require two options to achieve stability:

- in cases of total or partial edentulism, 2-3 lateral fixing pins (B) can be used and it may be necessary to use the drill pin (C) for insertion;
- in cases of total edentulism, the crestal fixing pins (D) are also available after using the lance drill (3); in order to screw them we use the driver for mounters) (F)

METAL SLEEVE

For a confident guide and easy insertion of the lateral pins



CRESTAL FIXING PIN

Greater stability through the support of crestal bone

PIN DRILL

It facilitates the insertion of the lateral fixing pins

LATERAL FIXING PIN

They have the function of stabilizing the guide masks of a vestibular area

Ø	H	CODE
1.55mm ext 3.4mm	10	GD-BOG 1 cf x 4 pz
1.5	10	GD-FOG
1.5	20	GD-PING 1 cf x 4 pz

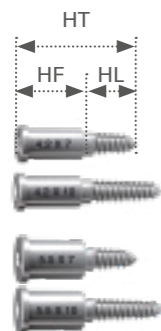

Ø PIN	HF Fix height	HL Labour height	HT Total height	CODE
Ø 4.2	9	7	17	GD-PIN/57
		10	19	GD-PIN/510
Ø 5.5	9	7	17	GD-PIN/67
		10	19	GD-PIN/610

INITIAL SURGICAL INSTRUMENTS

1 MUCOTOMES

There is a mucotome inside the kit that can be used alone with 4.2 mm diameter sleeves or combined with a converter (A) that allows it to be adapted to the larger diameter sleeve.

ONE FOR ALL DIAMETERS

Thanks to the converter it can also be used in 5.5 mm diameter sleeves.



LATERAL HOLE

It allows for the drainage of liquids.

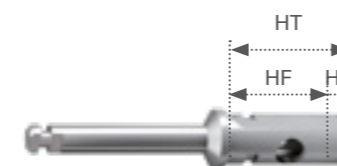

HF Fix height	HL Labour height	HT Total height	CODE
9	1	10	GD-263

RECOMMENDED SPEED: 100 rpm

2 CRESTAL LEVELLER

This drill is intended to level the work bone structure in order to provide better control of subsequent drills. The crestal leveller can be used separately with 4.2 mm diameter sleeves, but also in conjunction with the converter (A) for implant sites with 5.50 mm diameter sleeves.

ONE FOR ALL DIAMETERS

Thanks to the converter it can also be used in 5.5 mm diameter sleeves.

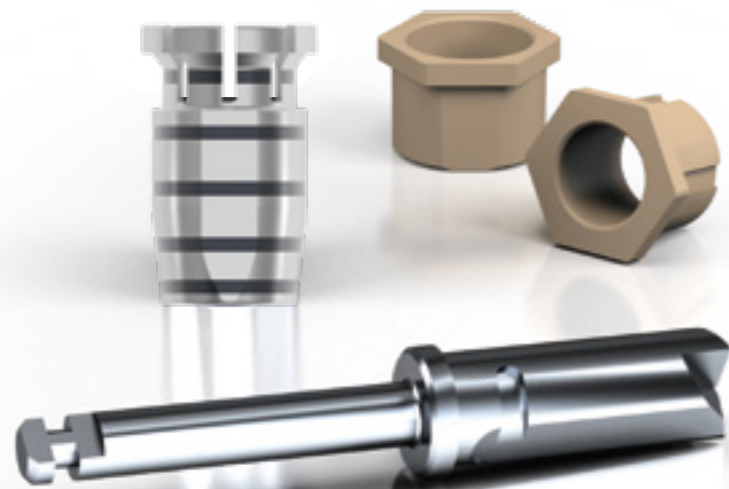

LIMITED CUTTING THICKNESS

The cutting surface allows for the levelling of a limited bone thickness.

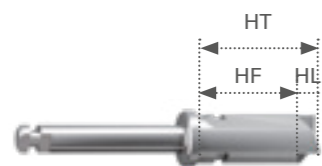

HF Fix height	HL Labour height	HT Total height	CODE
9	2	11	GD-264

RECOMMENDED SPEED: 300 rpm

3 LANCE DRILL

The next step consists of a lance drill which has the function of creating a hole in the cortical tissue with a depth of 6.00 mm that permits a guide and the greater stability of successive drills. The lance drill can be used separately or combined with a converter (A) to fit the 5.5 mm diameter sleeve.

ONE FOR ALL DIAMETERS

It can also be used in 5.5 mm diameter sleeves thanks to the converter.



PENETRATING TIP

It has the function of piercing the cortical bone and decreasing the resistance on subsequent drills.

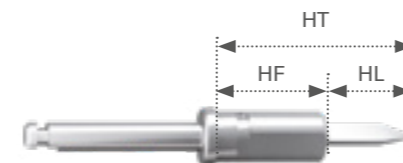

HF Fix height	HL Labour height	HT Total height	CODE
9	7	16	GD-LANCIA

RECOMMENDED SPEED: spongy bone 350 - 600 rpm
hard bone 800 - 1000 rpm

PREPARATION INSTRUMENTS

4 GUIDED DRILLS

The drills for the preparation of Slim, 3P and EV lines have the same external geometry and differ in diameters and different conformations of the threads. Given the common cylinder-conical morphology for the preparation of the site, the same drills are used. The preparation drills have a cylindrical-conical shape with a two-edged helical geometry in drills of up to 3.00 mm, while there are 4 straight-tooth blades in upper diameter drills. To facilitate the choice of drills during surgery, all the preparation instruments are equipped with a coloured o-ring that allows you to easily identify the drill depending on the diameter of the chosen implant.



COLORED O-RINGS

The colour classification allows for an easy identification of the drill suitable for the implant diameter.

LASER ETCHING

They identify the diameters and lengths of the corresponding implants.

CONVERTER

For the adaption of drills with diameters of up to 4 mm to 5.5 mm sleeves. Press-fit and easy release.

Add 0.5 mm to the length of the drill, taking into account the sharp angled tip.

NOTE

Always bring the drills to the full-travel stop making sure to use the cooling systems to avoid excessive overheating. The drills prepare an osteotomy increased by 0.5 mm compared to the length of the implant.

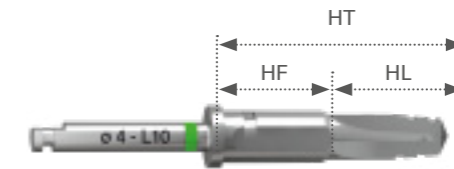

Ø DRILL	HF Fix height	HL Labour height	HT Total height	Ø NECK	CODE
Ø 2.1	9	8.5	17.5	4.2	GD-21-08
		10.5	19.5		GD-21-10
		12.5	21.5		GD-21-12
		14.5	23.5		GD-21-14
Ø 3	9	8.5	17.5	4.2	GD-30-08
		10.5	19.5		GD-30-10
		12.5	21.5		GD-30-12
		14.5	23.5		GD-30-14
Ø 3.5	9	8.5	17.5	4.2	GD-35-08
		10.5	19.5		GD-35-10
		12.5	21.5		GD-35-12
		14.5	23.5		GD-35-14
Ø 4	9	8.5	17.5	4.2	GD-40-08
		10.5	19.5		GD-40-10
		12.5	21.5		GD-40-12
		14.5	23.5		GD-40-14
Ø 4.5	9	8.5	17.5	5.5	GD-45-08
		10.5	19.5		GD-45-10
		12.5	21.5		GD-45-12
		14.5	23.5		GD-45-14
Ø 5	9	8.5	17.5	5.5	GD-50-08
		10.5	19.5		GD-50-10
		12.5	21.5		GD-50-12
		14.5	23.5		GD-50-14

RECOMMENDED SPEED: spongy bone 350 - 600 rpm
hard bone 800 - 1000 rpm

5 COUNTERSINK DRILLS

Countersink drills are used to shape the cortical bone where there is highly compact bone.

COLORED O-RINGS

The colour classification allows for an easy identification of the drill suitable for the implant diameter.



LASER ETCHING

They identify the diameters and lengths of the corresponding implants

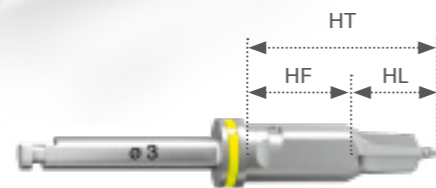

Ø DRILL	HF Fix height	HL Labour height	HT Total height	CODE
Ø 3	9	6	15	GD-SV-30
Ø 3.5				GD-SV-35
Ø 4				GD-SV-40
Ø 4.5				GD-SV-45
Ø 5				GD-SV-50

RECOMMENDED SPEED: spongy bone 350 - 600 rpm
hard bone 800 - 1000 rpm

6 COMPACTORS

In the case where, on the contrary, the bone is not very dense, compactors can be used to achieve better conditions to obtain greater primary stability. The rounded tip of these instruments makes them suitable even in cases of osteotomies in areas surrounding the sinus.



COLORED O-RINGS

The colour classification allows for an easy identification of the drill suitable for the implant diameter.

LASER ETCHING

They identify the diameters and lengths of the corresponding implants.

NOTE

The compactors should not be screwed to the end, the laser markings identify the length of the preparation.

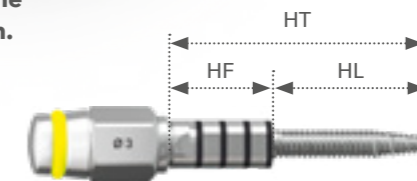

Ø COMPACTORS	HF Fix height	HL Labour height	HT Total height	CODE
Ø 2.1	9	14.3	23.3	GD-761/2
Ø 3				GD-761/2A
Ø 3.5				GD-761/3A
Ø 4				GD-761/4A
Ø 4.5				GD-761/5A
Ø 5				GD-761/6A

RECOMMENDED SPEED: manual insertion with moderate speed

MOUNTERS AND DRIVERS

E MOUNTERS AND P MOUNTER EXTRACTOR

The mounters have the function of guiding the final insertion of the implant in terms of angulation, height and orientation. This component has a repeating hexagon with faces that are aligned with those of the implant connections that guides the operator during insertion. The faces of the hexagon must be made to match the direction of the sleeve inside the guide. The mouter extractor (P) helps the insertion of the mounters from the surgical templates by levering them in the dedicated lateral lodge on the mounters.



COLOR CODED
To help choosing the right height and diameter.

LATERAL LODGE
For an easy extraction from the surgical template.



Ø IMPLANT	HEIGHT	CODE
Ø 3	0	GD-768/3
	+2	GD-768/32
	+4	GD-768/34
Ø 3.5 - 4	0	GD-768/1
	+2	GD-768/12
	+4	GD-768/14
Ø 4.5 - 5	0	GD-768/2
	+2	GD-768/22
	+4	GD-768/24

RECOMMENDED TORQUE:
50 N/cm

F DRIVER FOR MOUNTERS

There is a driver for mounters inside the surgical kit used to transport the mounters and implants inside the mouth and screw the implant. The mouter is provided with an internal screw that must be screwed onto the implant; the driver will then be anchored to the mouter before extracting the implant from the blister pack. Once the implant has been inserted and the internal screw of the mouter unscrewed, it should be helpful to use the extractor (P) mounted on the straight manual key (L) to remove the mounters from the sleeves using it as a lever in the dedicated lateral lodges.

G DIRECT DRIVERS

This driver allows the implant to be transported via a spring-loaded attachment mechanism. It is available in two diameters (for SLIM implants marked with a yellow o-ring and for 3P and EV line implants); they can be used separately with 4.2 mm diameter sleeves, but also in combination with the converter (A) for implant sites with 5.5 mm diameter sleeves.

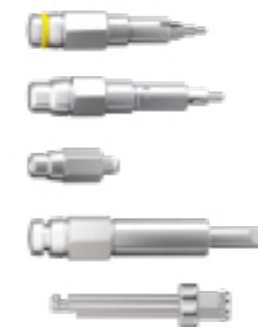

Ø IMPLANT	HEIGHT	CODE
Ø 3	17	GD-00578
Ø 3.5 - 4 - 4.5 - 5	15	GD-701
Ø 3.5 - 4 - 4.5 - 5	-	GD-769
-	-	GD-776
-	19.5	GD-00778

MAXIMUM TORQUE ALLOWED:
50 N/cm

KEYS, RATCHETS & EXTRACTOR





H PROSTHETIC SCREWDRIVERS

There are two screw drivers in the kit, one short and one long which can be used either manually or coupled to the torque ratchet, necessary for screwing and unscrewing the mounter screws, locking screws, transgingival screws and abutment fixing screws.

PROSTHETIC SCREWDRIVERS
Two measurements to reach all sites

Q EXTRACTOR KEY

When two conical surfaces connect with each other, a 'morse' or clamping effect is created and the two parts (implant and abutment) lock together. This effect can be cancelled by inserting an extraction screw.

	HEIGHT	CODE
	23	INN-61000* *
	29.5	INN-61000L* *
	32	INN-6161*
	36	INN-6161L

EXTRACTOR KEY
To retrieve the abutments from the implants



**** RECOMMENDED TORQUE:**
25 N/cm
** NOT included*

I RATCHETS AND L STRAIGHT MANUAL KEY

The kit is provided with two ratchets, a dynamometric one and a fixed one, to allow you to work by controlling both the screwing force (up to 50 N/cm) as well as applying greater force. The screwing limits beyond which risk breakage are 25 N/cm per the prosthetic 3P and EV screws, 20 N/cm for the screws of the SLIM implants, and 15 N/cm for the MUA and flat abutment screws. The ratchets can be used in function IN (screw) or OUT (unscrew) by changing the side of use. The key is used to manually insert the implant allowing for the direct application of force. Thanks to the secure grip, it provides a firm hold.



ADJUSTABLE TORQUE
By turning the end, the tightening torque can be adjusted from 0-50 with the possibility of transforming it into a fixed ratchet (∞).

Warning: torque adjustment on a torque ratchet is done by means of a ferrule placed on the handle of the instrument.

HEIGHT	CODE
90	00376DIN
90	00376
50	3P-00090CM

COMPONENTS FOR MUA

MREAMER NO POSITIONERS

The reamer, used once the implant is installed, has the function of modelling the cortical bone structure around the implant platform. The positioners allow for an easy positioning of the multi-unit abutments (MUA).

The positioner for the straight MUA hooks onto the component vertically, while the one for the angled MUA is screwed into the insertion hole of the fixing screw, leaving the hole free for the implant attachment screw.

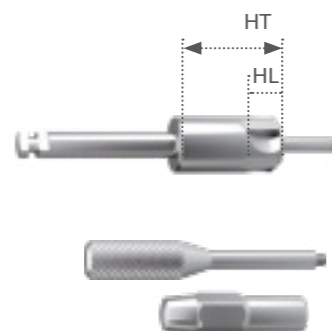

RECOMMENDED TORQUE:
15 N/cm

HL Labour height	HT Total height	CODE
3.5	15	GD-BM

HL	CODE
25	023-MUA
23	INN-00637

OFFSETS FOR ENHANCED SOFT TISSUE THICKNESSES

GENERAL MEASUREMENTS

In order to determine the final position of the implant, and choose the appropriate length of drills, mounters and accessories, it is necessary to keep in mind the following dimensions: B & B Dental implants should be positioned 1 mm under the crest to permit the platform switching effect that makes for an effective result when combined with the cone morse connection that characterizes our implants.

There are 3 series of mounters (0, +2 and +4): height 0 mounters are those normally used when the external opening of the sleeve is positioned 9 mm above the level of the implant platform; the other heights, +2 and +4, are useful in cases where the mucosa is thicker in order to avoid the opening of a flap or gengivoplasty, therefore requiring a decision to raise the level of the sleeve during the planning stage. In this second case, it is necessary to use the drills and the preparing instruments for the osteotomy with an enhanced length according to the position +2 and +4 of the sleeve. For example, 10 mm implant length with a sleeve in a +2 position, the final drill will be 12 mm length.

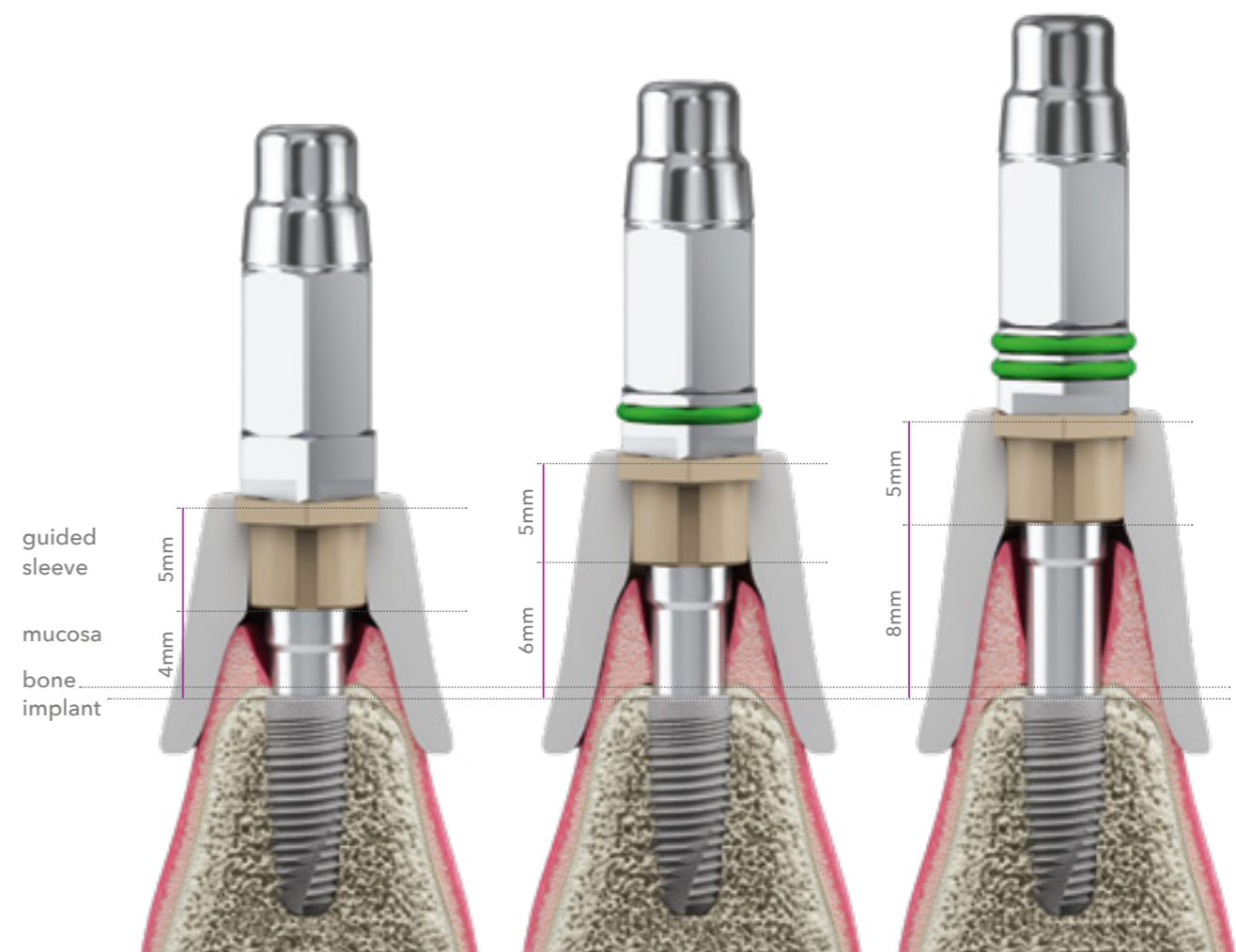

NB: with the sleeve in position +2, you can insert implants up until the maximum length of 12 mm.

NB: with the sleeve in position +4, you can insert implants up until the maximum length of 10 mm.

GUIDED SURGERY KIT +2 +4 OFFSET

The +2 and +4 kit is used when sleeve offset is displaced to accommodate implants up to 14 mm in length.

Add 0.5 mm to the length of the drill, taking into account the sharp angled tip.



LASER ETCHING

They identify the diameters and lengths of the corresponding implants.

COLORED O-RINGS

The colour classification allows for an easy identification of the drill suitable for the implant diameter.

CONVERTER

For the adaption of drills with diameters of up to 4 mm to 5.5 mm sleeves. Press-fit and easy release.



KIT OFFSET + 2 + 4
3D-00093PLUS



Ø DRILL	HF Fixed height	HL Engaging	HT Total height	Ø COLLAR	CODE
Ø 2.1	9	16.5	25.5	4.2	GD-21-16
		18.5	27.5		GD-21-18
Ø 3	9	16.5	25.5	4.2	GD-30-16
		18.5	27.5		GD-30-18
Ø 3.5	9	16.5	25.5	4.2	GD-35-16
		18.5	27.5		GD-35-18
Ø 4	9	16.5	25.5	4.2	GD-40-16
		18.5	27.5		GD-40-18
Ø 4.5	9	16.5	25.5	4.2	GD-45-16
		18.5	27.5		GD-45-18
Ø 5	9	16.5	25.5	4.2	GD-50-16
		18.5	27.5		GD-50-18

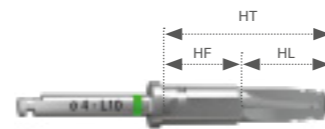

GUIDE SYSTEM SOFTWARE GUIDE YOUR SURGERIES TO PERFECTION

The guided surgery service is built around your skills and needs and includes a set of tools and technical support tailored to you, that improve the way you work and help you implement the digital workflow in your practice.

A software that can be downloaded from B&B Dental website and that is clear, user-friendly, suitable for any device that allows you to view CBCTs, convert DICOM files to STL, plan your cases, leaving you the freedom to work independently but facilitating sharing information with our technicians before finalising.

B&B DENTAL GS SOFTWARE

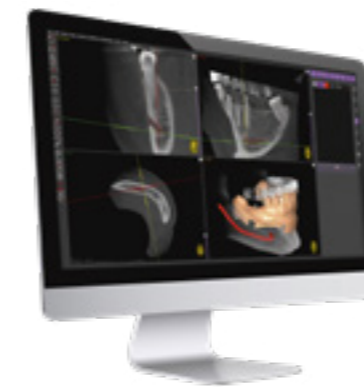

matching



implant planning and placement



template manufacturing

Once the implant project for implant placement has been prepared, the prosthetic structure can be prepared for immediate or conventional loading.

PROTOCOL



4.2 MM Ø SLEEVE

The drills are to be used successively in order to prepare the implant site to a size suitable for the implant to be placed in position. It is important to assess the hardness of the bone as hard bone may need the use of countersink drill to decrease the resistance given by the cortical bone. In cases where the bone is spongy, the use of compactors may be necessary to obtain primary stability.

HARD BONE PROTOCOL

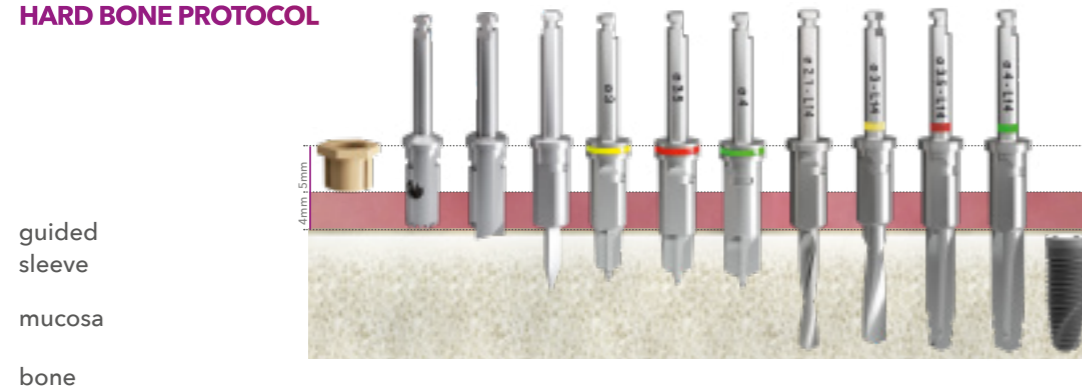

SPONGY BONE PROTOCOL

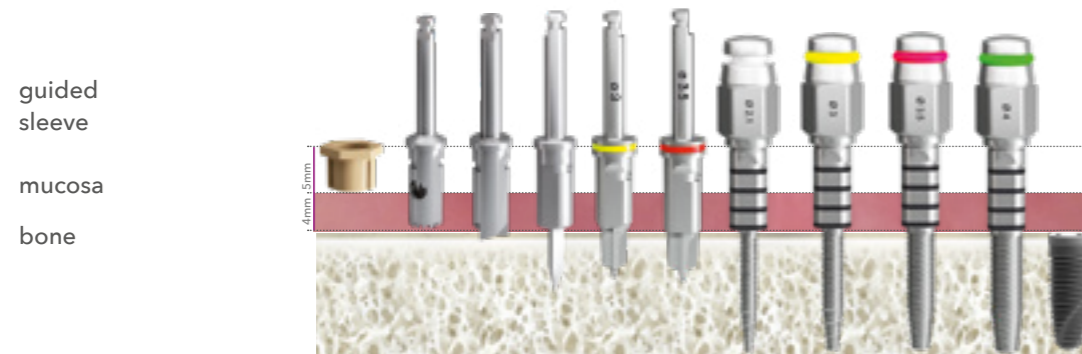
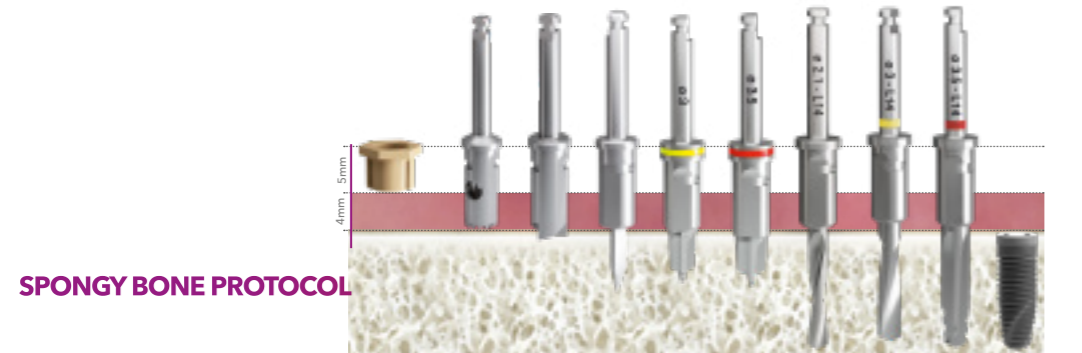

RECOMMENDED SPEED: spongy bone 350 - 600 rpm
hard bone 800 - 1000 rpm

NOTE

Always bring the drills to the full-travel stop making sure to use the cooling systems to avoid excessive overheating. The drills prepare an osteotomy increased by 0.5 mm compared to the length of the implant.

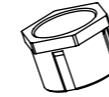

5.5 MM Ø SLEEVE

The first drills for the preparation of the osteotomy with 5.5 mm sleeves diameter must be coupled to the converter, allowing for a guided insertion into the sleeve. Larger diameter drills are already prepared with a neck diameter suitable for the wide sleeve.

HARD BONE PROTOCOL



SPONGY BONE PROTOCOL

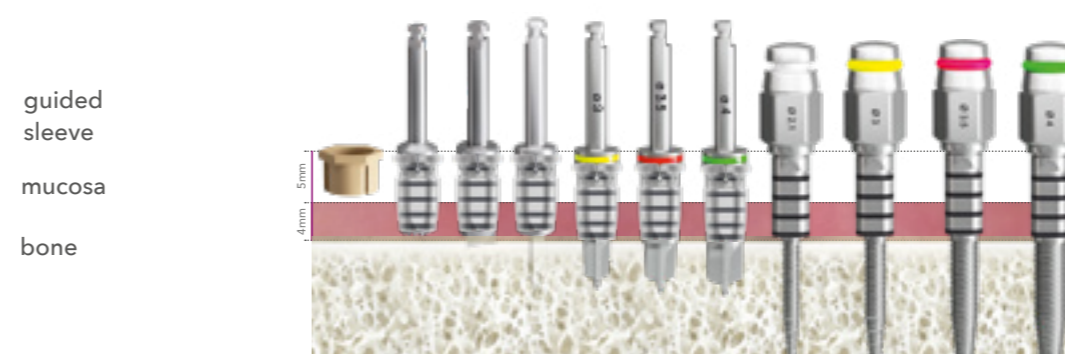
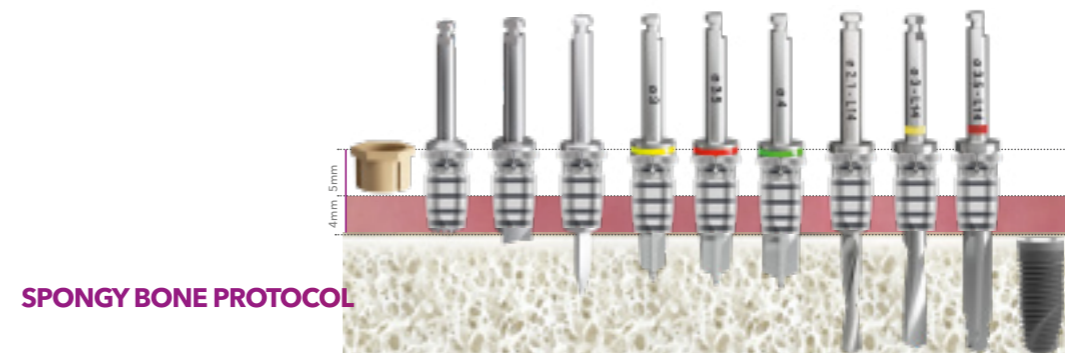

EV-3P LINE

BONE D1 D2



* add converter cod. GD-708

offset +2

IMPLANT	UPPER DIAMETER (mm)	SLEEVE	ANALOGUE	MUCOTOME	CRESTAL LEVELLER	LANCE DRILL															CUTTING EDGE LENGHT (MM) -LAST DRILL-						
3P-3508	3,50	GD-764P	3D-00585	GD-263	GD-264	GD-LANCIA		GD-SV-30	GD-SV-35	GD-21-08	GD-30-08	GD-35-08									8,00						
3P-3510							GD-SV-30	GD-SV-35	GD-21-10	GD-30-10	GD-35-10															10,00	
3P-3512							GD-SV-30	GD-SV-35	GD-21-12	GD-30-12	GD-35-12																12,00
3P-3514							GD-SV-30	GD-SV-35	GD-21-14	GD-30-14	GD-35-14																14,00
3P-4006#	4,00	GD-764P	3D-00585	GD-263	GD-264	GD-LANCIA		GD-SV-30	GD-SV-35	GD-SV-40	GD-21-08	GD-30-08	GD-35-08	GD-40-08								8,00					
3P-4008							GD-SV-30	GD-SV-35	GD-SV-40	GD-21-08	GD-30-08	GD-35-08	GD-40-08													8,00	
3P-4010							GD-SV-30	GD-SV-35	GD-SV-40	GD-21-10	GD-30-10	GD-35-10	GD-40-10														10,00
3P-4012							GD-SV-30	GD-SV-35	GD-SV-40	GD-21-12	GD-30-12	GD-35-12	GD-40-12														12,00
3P-4014							GD-SV-30	GD-SV-35	GD-SV-40	GD-21-14	GD-30-14	GD-35-14	GD-40-14														14,00
3P-4508	4,50	GD-765P*	3D-00585*	GD-263*	GD-264*	GD-LANCIA*		GD-SV-30*	GD-SV-35*	GD-SV-40*	GD-SV-45	GD-21-08*	GD-30-08*	GD-35-08*	GD-40-08*	GD-45-08						8,00					
3P-4510							GD-SV-30*	GD-DV-35*	GD-SV-40*	GD-DV-45	GD-21-10*	GD-30-10*	GD-35-10*	GD-40-10*	GD-45-10											10,00	
3P-4512							GD-SV-30*	GD-SV-35*	GD-SV-40*	GD-SV-45	GD-21-12*	GD-30-12*	GD-35-12*	GD-40-12*	GD-45-12												12,00
3P-4514							GD-SV-30*	GD-SV-35*	GD-SV-40*	GD-SV-45	GD-21-14*	GD-30-14*	GD-35-14*	GD-40-14*	GD-45-14												14,00
3P-5006#	5,00	GD-765P*	3D-00585*	GD-263*	GD-264*	GD-LANCIA*		GD-SV-30*	GD-SV-35*	GD-SV-40*	GD-SV-45	GD-SV-50	GD-21-08*	GD-30-08*	GD-35-08*	GD-40-08*	GD-45-08	GD-50-08				8,00					
3P-5008							GD-SV-30*	GD-SV-35*	GD-SV-40*	GD-SV-45	GD-SV-50	GD-21-08*	GD-30-08*	GD-35-08*	GD-40-08*	GD-45-08	GD-50-08									8,00	
3P-5010							GD-SV-30*	GD-SV-35*	GD-SV-40*	GD-SV-45	GD-SV-50	GD-21-10*	GD-30-10*	GD-35-10*	GD-40-10*	GD-45-10	GD-50-10									10,00	
3P-5012							GD-SV-30*	GD-SV-35*	GD-SV-40*	GD-SV-45	GD-SV-50	GD-21-12*	GD-30-12*	GD-35-12*	GD-40-12*	GD-45-12	GD-50-12										12,00
3P-5014							GD-SV-30*	GD-SV-35*	GD-SV-40*	GD-SV-45	GD-SV-50	GD-21-14*	GD-30-14*	GD-35-14*	GD-40-14*	GD-45-14	GD-50-14										14,00
EV-4008	4,00	GD-764P	3D-00585	GD-263	GD-264	GD-LANCIA		GD-SV-30	GD-SV-35	GD-SV-40	GD-21-08	GD-30-08	GD-35-08									8,00					
EV-4010							GD-SV-30	GD-SV-35	GD-SV-40	GD-21-10	GD-30-10	GD-35-10														10,00	
EV-4012							GD-SV-30	GD-SV-35	GD-SV-40	GD-21-12	GD-30-12	GD-35-12															12,00
EV-4014							GD-SV-30	GD-SV-35	GD-SV-40	GD-21-14	GD-30-14	GD-35-14															14,00
EV-4506#	4,50	GD-765P*	3D-00585*	GD-263*	GD-264*	GD-LANCIA*		GD-SV-30*	GD-SV-35*	GD-SV-40*	GD-SV-45	GD-21-08*	GD-30-08*	GD-35-08*	GD-40-08*							8,00					
EV-4508							GD-SV-30*	GD-SV-35*	GD-SV-40*	GD-SV-45	GD-21-08*	GD-30-08*	GD-35-08*	GD-40-08*												8,00	
EV-4510							GD-SV-30*	GD-SV-35*	GD-SV-40*	GD-SV-45	GD-21-10*	GD-30-10*	GD-35-10*	GD-40-10*													10,00
EV-4512							GD-SV-30*	GD-SV-35*	GD-SV-40*	GD-SV-45	GD-21-12*	GD-30-12*	GD-35-12*	GD-40-12*													12,00
EV-4514							GD-SV-30*	GD-SV-35*	GD-SV-40*	GD-SV-45	GD-21-14*	GD-30-14*	GD-35-14*	GD-40-14*													14,00
EV-5006#	5,00	GD-765P*	3D-00585*	GD-263*	GD-264*	GD-LANCIA*		GD-SV-30*	GD-SV-35*	GD-SV-40*	GD-SV-45	GD-SV-50	GD-21-08*	GD-30-08*	GD-35-08*	GD-40-08*	GD-45-08					8,00					
EV-5008							GD-SV-30*	GD-SV-35*	GD-SV-40*	GD-SV-45	GD-SV-50	GD-21-08*	GD-30-08*	GD-35-08*	GD-40-08*	GD-45-08										8,00	
EV-5010							GD-SV-30*	GD-SV-35*	GD-SV-40*	GD-SV-45	GD-SV-50	GD-21-10*	GD-30-10*	GD-35-10*	GD-40-10*	GD-45-10											10,00
EV-5012							GD-SV-30*	GD-SV-35*	GD-SV-40*	GD-SV-45	GD-SV-50	GD-21-12*	GD-30-12*	GD-35-12*	GD-40-12*	GD-45-12											12,00
EV-5014							GD-SV-30*	GD-SV-35*	GD-SV-40*	GD-SV-45	GD-SV-50	GD-21-14*	GD-30-14*	GD-35-14*	GD-40-14*	GD-45-14											14,00

SLIM LINE

IMPLANT	UPPER DIAMETER (mm)	LOWER DIAMETER (mm)	SLEEVE	ANALOGUE	MUCOTOME	CRESTAL LEVELLER	LANCE DRILL				CUTTING EDGE LENGHT (MM) -LAST DRILL-	
SL-3408	3,40	3,00	GD-764P	3D-0097AN/1	GD-263	GD-264	GD-LANCIA		GD-SV-30	GD-21-08	GD-30-08	8,00
SL-3410								GD-SV-30	GD-21-10	GD-30-10	10,00	
SL-3412								GD-SV-30	GD-21-12	GD-30-12	12,00	
SL-3414								GD-SV-30	GD-21-14	GD-30-14	14,00	
3P-3008	3,00	2,40	GD-764P	3D-0097AN/1	GD-263	GD-264	GD-LANCIA		GD-SV-30	GD-21-08	GD-30-08	8,00
3P-3010								GD-SV-30	GD-21-10	GD-30-10	10,00	
3P-3012								GD-SV-30	GD-21-12	GD-30-12	12,00	
3P-3014								GD-SV-30	GD-21-14	GD-30-14	14,00	

NOTE

Always bring the drills to the full-travel stop making sure to use the cooling systems to avoid excessive overheating. The drills prepare an osteotomy increased by 0.5 mm compared to the length of the implant.

PACKAGING

The new packaging is safer and more practical thanks to its anti-tampering opening. Implant holder vial keeps the implant in position, ready to be picked up using ratchet or contra-angle drivers. In each implant packaging a healing screw and a cover cap are included.



SEALED PACKAGING
When packaging is sealed, the symbol is a closed lock of a neutral colour.



OPEN PACKAGING
After opening, the tab becomes red, with an open lock.

EV
4.0 x 12
RED LABEL
Line name, diameter, length



- 1 Open the external vial by pulling the tab on the side of the cap.
- 2 Remove the internal ampoule.
- 3 Remove the cap of the second vial.

INDIRECT PHASE



- 4a Engage the fitter (E) (selected according to the type of implant and the diameter of the sleeve) on the implant placed inside the ampoule and screw the implant connection with the hexagonal key.
- 5a Insert the mounter driver (F) inside the mount connection.
- 6a Withdraw the implant and place it into the surgical site.

DIRECT PHASE



- 4b Insert the direct driver (G) (selected according to the type of implant - insert the converter in cases where there is a larger diameter sleeve) inside the implant connection paying attention that it fits perfectly.

DIGITAL FRAMEWORKS STRUCTURED TO LAST

The milling center was established as a reference point for the processing and creation of the structures based on your projects, whether for immediate loading after a guided surgery or in general to create the prosthesis for your patients.

If you are already an experienced user we can provide you with the libraries to work in a total independent way or you can provide us with the STL files for milling purposes.

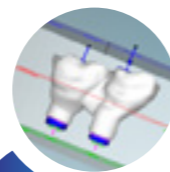

We guide you till the end because thanks to the equipment at our center we can prepare the structures according to the purposes and materials you want.



Our team is here for you, to help you design your prosthetic structures whether you want to finalise them with us, in collaboration with your laboratory, or directly with your trusted laboratory.

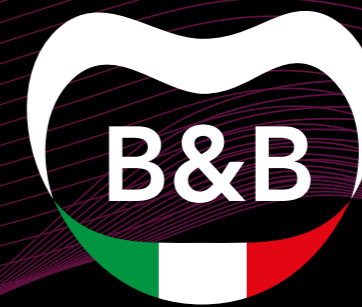
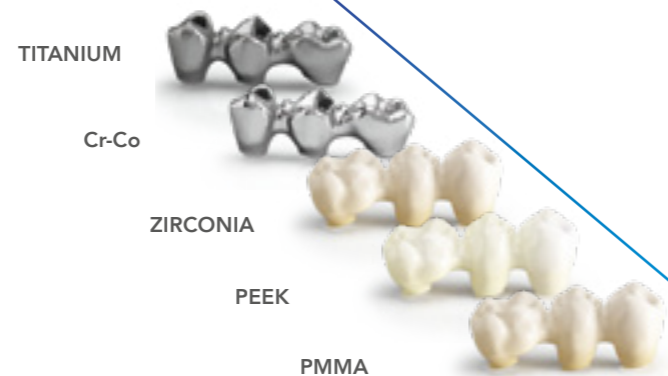

CONTACTS

OFFICIAL DISTRIBUTOR -

DENTOMY SDN BHD
13A-02, Menara 1MK, No.1,
Jalan Kiara, Mont Kiara,
50480 Kuala Lumpur, Malaysia

☎ +60 12-250 2052
+60 13-388 1268

✉ connect@dentomy.co

🌐 www.bebdentalmalaysia.com
