

An elephant's head and trunk are shown against a black background. The left side of the elephant is lit with a warm, golden-yellow light, while the right side is in grayscale. The trunk is split vertically, with the left half matching the golden-yellow lighting and the right half in grayscale. A series of thin, golden-yellow wavy lines originate from the trunk and fan out across the lower half of the image. The text 'REGENERATION MATERIALS' is centered over the elephant's trunk in a bold, white, sans-serif font, with each letter of a word on a new line.

**R E G
E N E
R A T
I O N
M A T
E R I
A L S**



B&B DENTAL
IMPLANT COMPANY



INDEX

NOVOBONE

NOVOBONE GRANULES.....	4
------------------------	---

COLLAGEN T-BARRIER MEMBRANES

COLLAGEN T-BARRIER MEMBRANES.....	6
KEY PROPERTIES - COLLAGEN T-BARRIER MEMBRANES	7

TITANIUM T-BARRIER MEMBRANES

TITANIUM T-BARRIER MEMBRANES	8
OSTEOSYNTHESIS SCREWS	9

CLINICAL CASES

AESTHETIC-FUNCTIONAL RESTORATION IN FRONTAL POST-EXTRACTION SITE.....	10
IMPLANT WITH COMPLETE ABSENCE OF VESTIBULAR LAMELLAE - FOLLOW-UP AT 7 YEARS	11
VERTICAL BONE VOLUME RESTORATION	12

CUSTOMIZED MESH GRIDS

CUSTOMIZED MESH GRIDS.....	13
----------------------------	----

**READ THROUGH THE CLINICAL CASES
AND DISCOVER THE FULL RANGE OF B&B
DENTAL PRODUCTS**

VISIT THE SECTION OF THE WEBSITE AND
FILL OUT THE FORM TO SUBMIT YOUR CASES!



REGENERATION EXPLAINED

Regeneration in dentistry is a practice used to restore volume in both hard and soft tissues to recreate the aesthetic and functional balance of a certain area of the oral cavity.

In implantology, regeneration can facilitate implant placement or is also used to improve aesthetic results as it lends tissues a more natural appearance by creating profiles that are more in line with the physiognomy of the face or oral cavity.

B&B Dental has developed a comprehensive line of materials and tools to improve implant results. B&B Dental's philosophy is always that production starts with the careful selection of raw materials, which are then processed using innovative methods, in order to offer quality products that have passed strict scrutiny by our experts.

B&B Dental aims to become your trusted partner for your successful implant practice.



NOVOBONE

B&B Dental's product range expands with the introduction of Novobone Granules, an inert biocompatible material designed to support the dentist in need of the highest quality bone substitute for the resolution of clinical regenerative cases.

USE AND CHARACTERISTICS:

- Sinus lift
- Crestal volume augmentation
- Periodontal regeneration
- Alveolar regeneration
- Post-extraction regeneration

Novobone Granules is:

- compliant with the Regulation (EU) 2017/745 (**MDR**)
- treated at low temperature for the removal of the protein component
- 100% resorbable

The production and sales chain are entirely Italian.



PRODUCT FORMAT

REF.	DESCRIPTION	VOL.
NBG-0.5	GRANULES, 1 vial, 0.5 g, granules diameter: 0.2-0.6mm	1cc
NBG-1	GRANULES, 1 vial, 1 g, granules diameter: 0.2-0.6mm	2cc
NBG-2	GRANULES, 1 vial, 2 g, granules diameter: 0.2-0.6mm	4cc
NBG-3	GRANULES, 1 vial, 3 g, granules diameter: 0.2-0.6mm	6cc
NBG-5	GRANULES, 1 vial, 5 g, granules diameter: 0.2-0.6mm	10cc

The granules are made of bovine-derived hydroxyapatite that have undergone a thorough process of decellularization and deproteinization at low temperature. B&B Dental chose the cold treatment because, compared to the high temperature one, it avoids crystallization (ceramization) of the granules, which become completely biocompatible and resorbable.

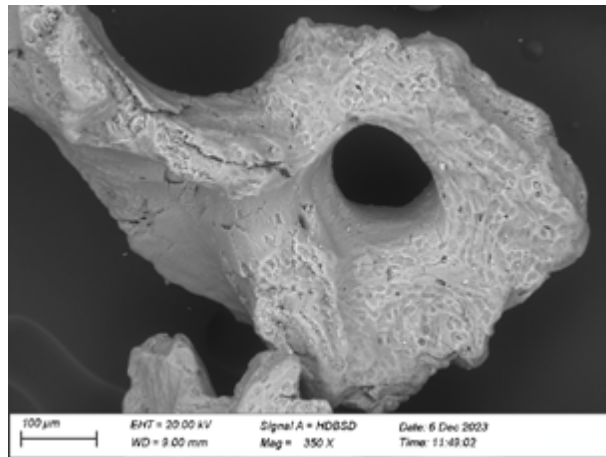
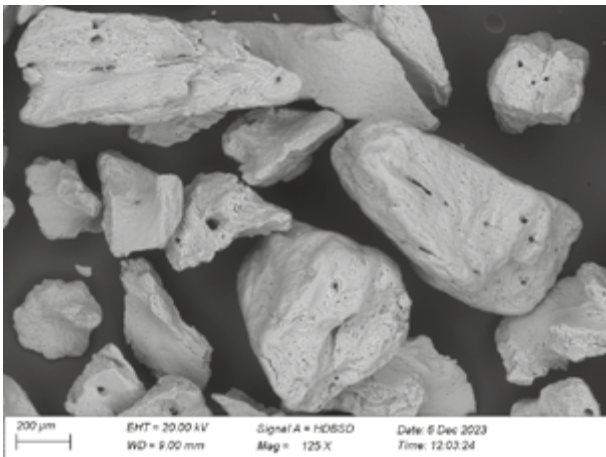

As demonstrated by relevant studies and scientific literature, B&B Dental granules adhere to precise physical characteristics to allow increased vascularization and tissue regeneration:

- Three-dimensional morphology
- Increased microrough surface
- High number of cavities
- Great porosity

This allows the granules to act as osteoconductors, remodeling themselves to replace the patient's endogenous tissue.

The advantages of these features are reflected in scientific data: the larger the surface area of the granule, the more the patient's active cells surrounding it are driven to colonize the area with new cells, the osteoblasts.

In addition, the conformation of the granule allows for tissue volumization for optimal aesthetic and functional effects.

The average resorption time of Novobone Granules is 6-9 months. For an ideal result, we recommend using the product in synergy with **T-Barrier Collagen** B&B Dental membranes.

CE marked product in accordance with Regulation (EU) 2017/745 (MDR).



COLLAGEN T-BARRIER MEMBRANES



Collagen T-Barrier Membrane is a resorbable membrane made from equine-derived collagen used to protect implant sites. It can be easily placed on the site after bone grafting and does not require fixation. The membrane provides a perfect basis for hard and soft tissue healing and creates a favourable environment for bone regeneration, as it allows osteogenic-cell growth in the site and avoids unwanted cell migration. It can also be used as a local haemostat.

T-Barrier Collagen also has the ability to act as a balanced barrier with controlled resorption, so as to avoid any inflammatory reaction in soft tissue.

T-Barrier Collagen is available in a wide range of sizes:

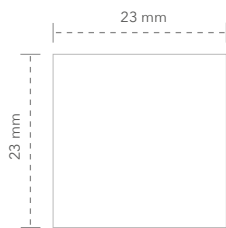

23 x 23 x 0,25 mm**
B-00223*

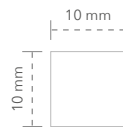

10 x 10 x 0,25 mm**
B-00223/1*

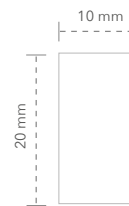

10 x 20 x 0,25 mm**
B-00223/2*

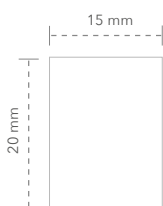

15 x 20 x 0,25 mm**
B-00223/3*

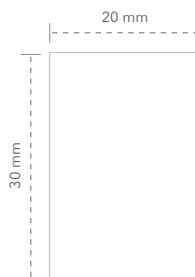

20 x 30 x 0,25 mm**
B-00223/4*

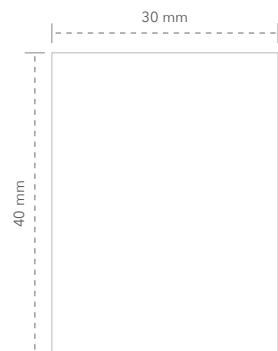

30 x 40 x 0,25 mm**
B-00223/5*

** ± 0.05 mm

* 2 membranes per pack

KEY PROPERTIES COLLAGEN T-BARRIER

Collagen T-barrier Membranes are membranes that can be used both in implant sites and to protect peri-implant bone defects or to treat small bone dehiscence defects. They may also be used to help repair small tears in the sinus membrane or to cover the access window in maxillary sinus augmentation procedures. They are also used to protect post-extraction cavities, as they improve and speed up healing while maintaining space.

Key properties of the membranes are as follows:

- Equine type I atellocollagen
- Safe and biocompatible
- Easy to apply
- Full resorption within 4 to 6 weeks

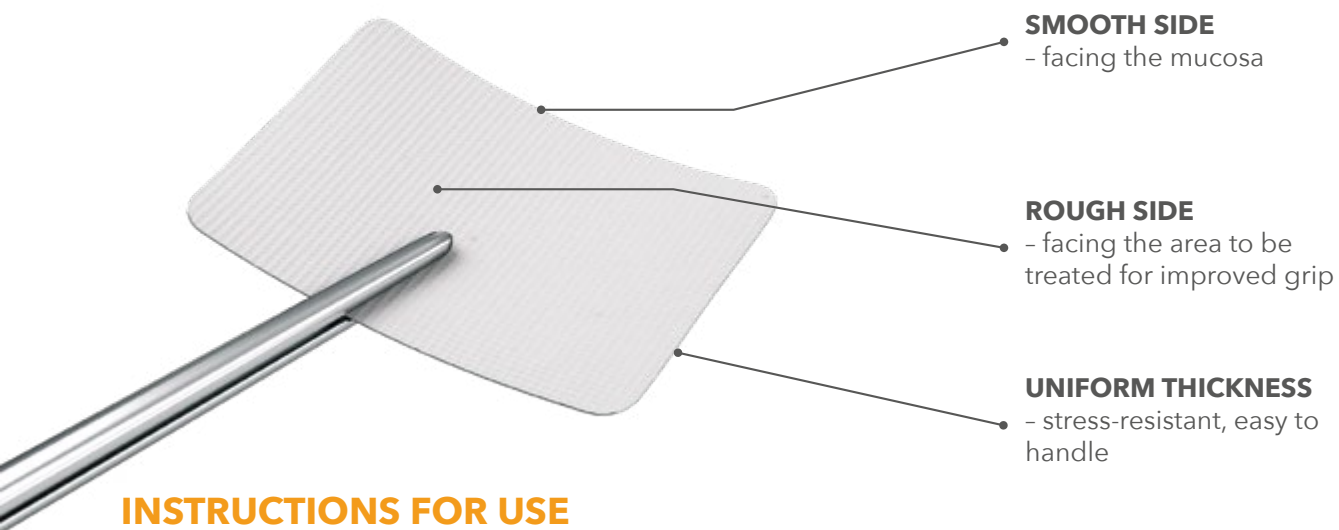

INSTRUCTIONS FOR USE

- The membrane can be cut and moulded into the desired shape.
- Hydrate the membrane in sterile saline solution at room temperature for a few minutes. If the site is bleeding, the membrane can be applied dry.
- Apply the membrane with the rough side facing the area to be treated under asepsis conditions and apply light pressure.
- Cover with the flap.



TITANIUM T-BARRIER MEMBRANES

Titanium T-Barrier membranes are titanium grids that are fixed to the implant with a fixation screw to prevent it from shifting within the sinus. Or they are fixed to the bone with osteosynthesis screws to keep the regeneration materials in place in the site. These grids are easy to mould into a shape that will fit the crestal bone.

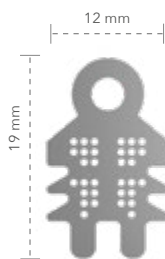

00532/3+

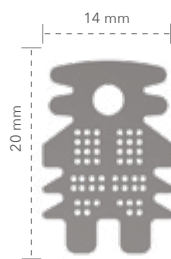

00532/4+

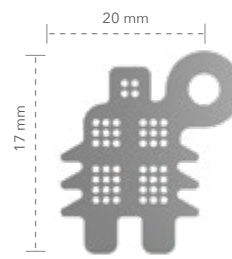

00532/5+

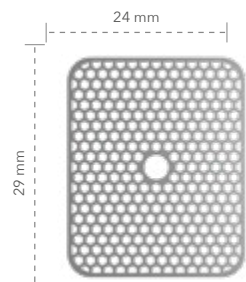

00532/12+



00532/10+

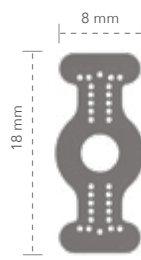

00532/1+



00532/2+

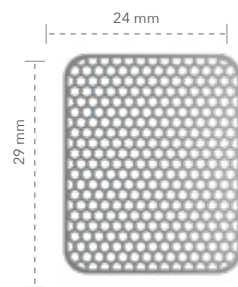

00532+

*1 pc per pack
thickness 0.13 mm



* Fixation screw 00532SCREW
included

OSTEOSYNTHESIS SCREWS

Osteosynthesis screws have a very sharp thread to facilitate insertion. Their cross head helps the screw stay engaged with the suitable screwdriver.

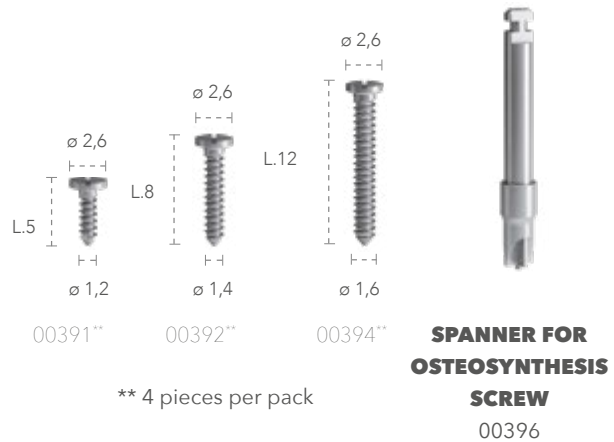

Osteosynthesis screws can be used to fix all (titanium and collagen) T-barrier membranes. Membranes can be used for both the upper and lower dental arches of patients with bone defects that would otherwise prevent implant treatment or pose serious constraints. The membranes are easy to cut and come in sterile packs ready for immediate use.

INSTRUCTIONS FOR USE

- Open the pack and remove the membrane
- Bend and mould the membrane so as to fit the area to be treated
- Insert the osteosynthesis screws or the fixation screw to secure the membrane in place.

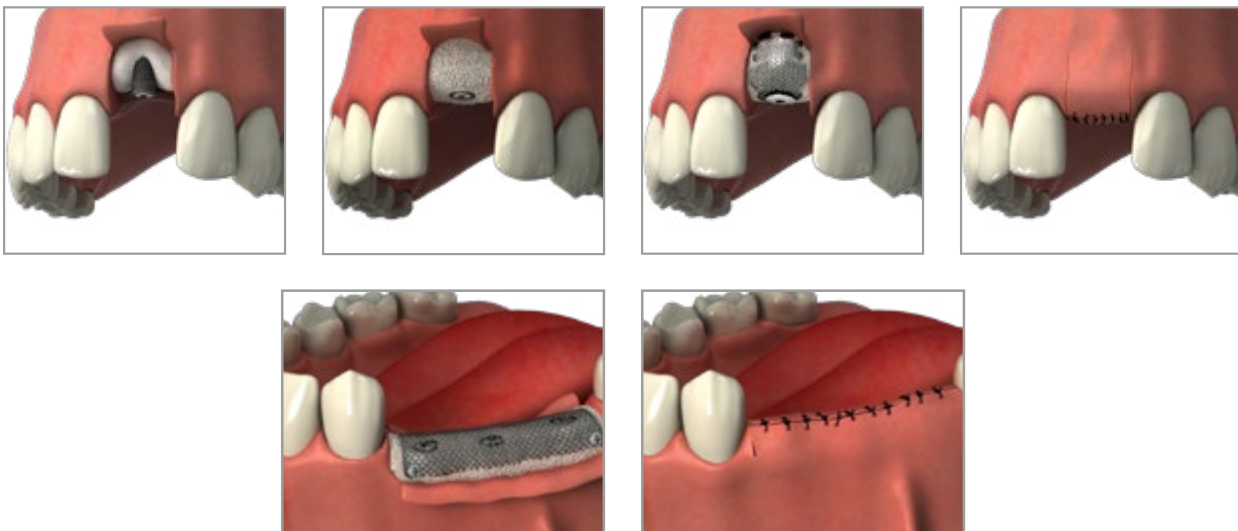

CLINICAL CASES

AESTHETIC-FUNCTIONAL RESTORATION IN FRONTAL POST-EXTRACTION SITE

ALESSANDRO CECCHERINI

The treatment plan for this patient consists in the placement of an EV implant in the anterior area. Because the site is in a position of high aesthetic significance, volumes need to be preserved for an optimal aesthetic result.

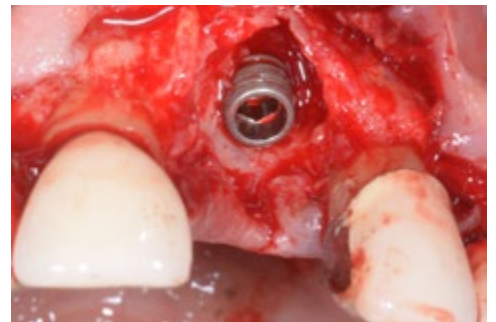

Extraction of compromised central incisor, cleaning of the cavity and insertion of an implant from the EV line - self-tapping thread, underprepared osteotomy - in post-extraction phase for improved bone volume maintenance.

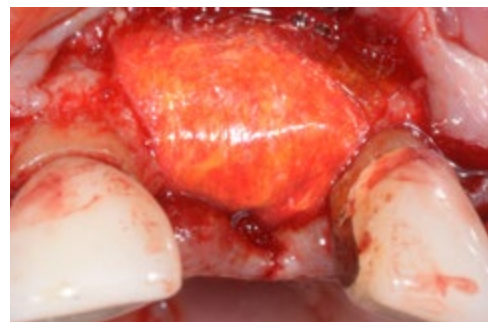

Because the implant was free of the vestibular lamellae, we opted for inserting bone regeneration material and cover the site with a collagen T-barrier membrane for enhanced healing and tissue maintenance.



Healing at 3 months. During this session, the flap was reopened to insert the healing screw and remodel the transmucosal contour.

IMPLANT WITH COMPLETE ABSENCE OF VESTIBULAR LAMELLAE FOLLOW-UP AT 7 YEARS

LUTFI UJAM

Upon presentation, the patient had had an incisor extracted a few months earlier and wished the aesthetics of their smile restored, preferably with a fixed restoration. Upon initial assessment, bone tissue exhibited a vertical bone dehiscence defect.



During the preparation of the osteotomy it was impossible to maintain the vestibular lamellae. Since the position has high aesthetic impact, it is necessary to restore frontal bone volume both for the long-term stability of the implant and the aesthetic result of the treatment.

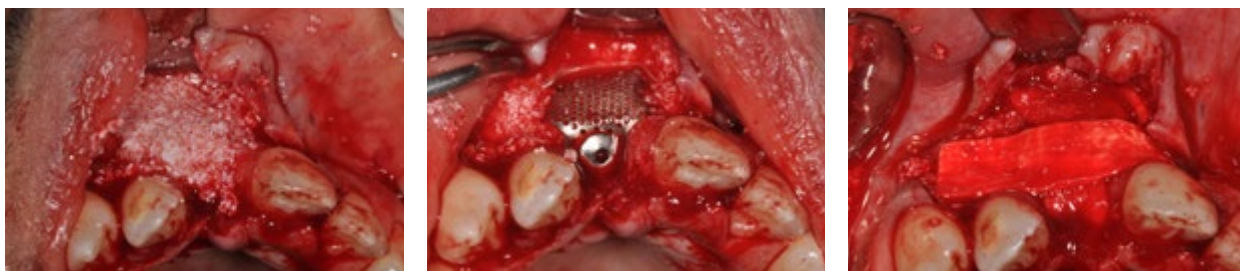

The procedure was carried out with a full-thickness flap with relieving incisions to obtain the broadest possible view. This facilitated the insertion of the bone regeneration material, the collagen membrane and the titanium membrane fixed to the implant.

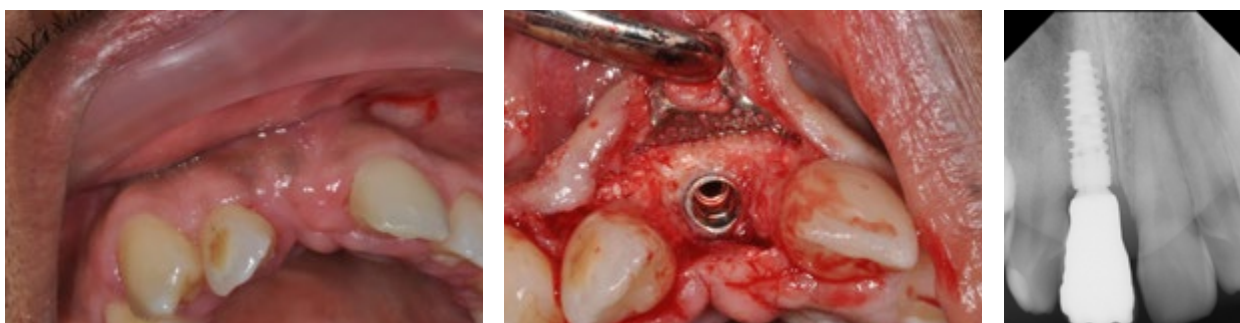

Four months after the first surgical procedure the tissues had healed properly and the flap was opened to remove the titanium membrane. Radiographic check 7 years after surgery: note volume maintenance and proper osseointegration.

VERTICAL BONE VOLUME RESTORATION

IOANA DATCU

Patient with vertical bone defect. The patient exhibits a resorbed saddle area that is not suitable for implant placement and a decision was made to wait for bone regeneration to occur before inserting B&B Dental implants.



Pre-op radiographic examination to assess the situation: apparent vertical bone defect with thin gingival morphotype. Full-thickness flap with relieving incisions and full detachment from the entire ridge.



Modelling and fitment of titanium T-barrier to suit ridge anatomy, grid is filled with bone regeneration material and fixed with 4 osteosynthesis screws. Dry collagen T-barrier membrane is added with rough side facing the mucosa for better adhesion.



Flap is reopened at 4 months and titanium T-barrier is removed. Soft tissue is keratinised and bone volume restored, and now support implant placement. Insertion of 3P and EV implants to suit bone density.

CUSTOMIZED MESH GRIDS

The customized meshes in titanium are used in GBR [guided bone regeneration] for vertical defects and in combined defects. Starting from the acquisition of a pre-operative CBCT [cone beam computed tomography], it is possible to obtain a virtual model on which to design and plan a digital grid. The STL is thus sent to the laboratory and the product is made via laser-sint technology, that is, a titanium 3D printing method.

The advantage compared to standard grids resides in the fact that the customized mesh is designed before the procedure, specifically for the anatomy of the patient. This therefore speeds up the execution, increasing intrinsic ability with a precise fixation: the degree of accuracy during the surgery is therefore extremely high. The titanium grids maintain a certain degree of elasticity that compensates for any possible inaccuracies, which are almost always linked to a non-optimal quality of CBCT.

Moreover, the design with rounded margins and smooth edges improves the healing of the overlying soft tissues, facilitating the passivation and suturing of the surgical flaps.

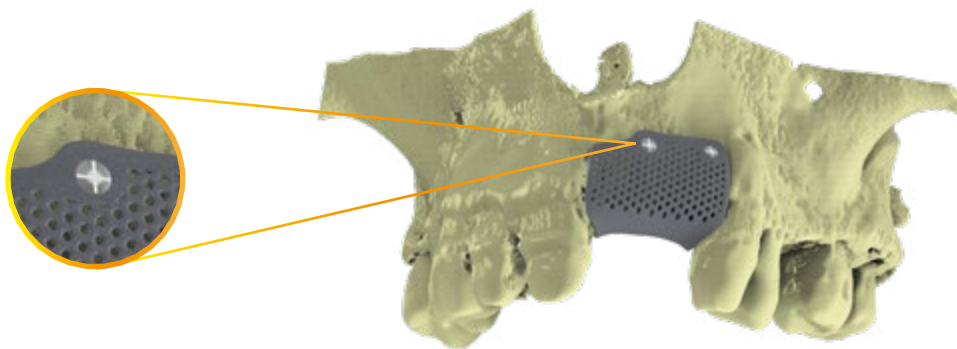

OSTEOSYNTHESIS SCREWS FOR MEMBRANES

Osteosynthesis screws can be used to fix the membranes so as to ensure their stability. They are available in three different heights and three diameters and they have a cross-shaped head. They can be inserted using a manual or contra-angle key.

IMPORTANT NOTE
See the Regeneration Materials Catalogue for the complete range of membranes.

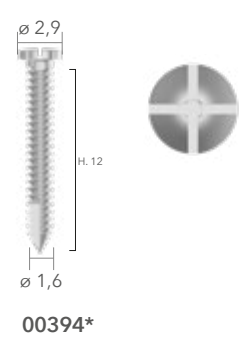
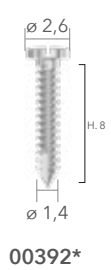
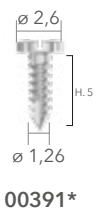
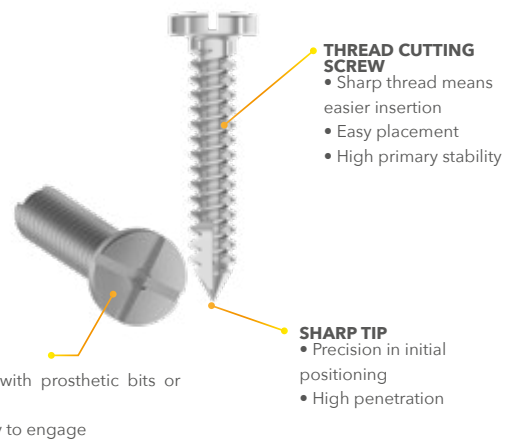

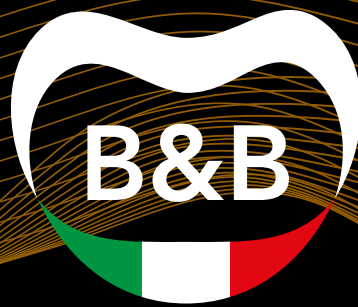

CONTACTS

OFFICIAL DISTRIBUTOR -

DENTOMY SDN BHD
13A-02, Menara 1MK, No.1,
Jalan Kiara, Mont Kiara,
50480 Kuala Lumpur, Malaysia

☎ +60 12-250 2052
+60 13-388 1268

✉ connect@dentomy.co

🌐 www.bebdentalmalaysia.com